

Squirrel-cage motors

Dimensions

Dimension sheet generator:

(part of the SD Configurator)

The SD Configurator contains a dimension drawing for each motor in this catalog. Provided that a complete Order No. is entered or parameterized with or without an order code, a dimension drawing can be called up under the "Documentation" tab.

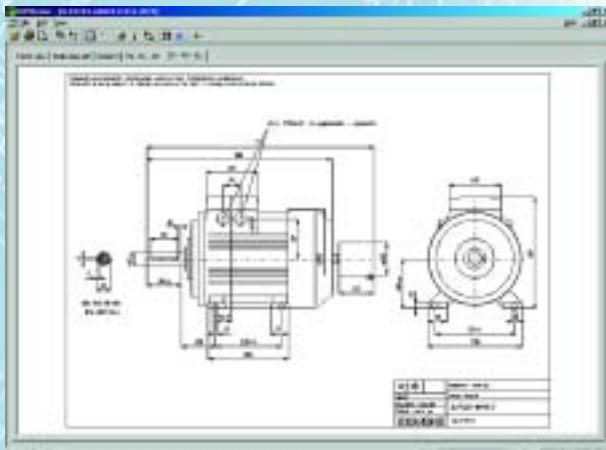

These dimension drawings can be presented and printed in various different views and windows.

The corresponding dimension drawings can be exported, saved and processed in DXF format (interchange/import format for CAD systems) or as bitmap graphics.

The SD configurator has been integrated into the electronic Catalog CA 01 as a selection aid (for further information see "Technical Information", "Configuration Aids").

The interactive catalog CA 01 can be ordered from your local Siemens sales representative or on the Internet under

<http://www.siemens.com/automation/CA01>

At this address, you will also find links to Tips and Tricks, and downloads for updating the functions or content.

Order No. of the CA 01 10/2003 German
E86060-D4001-A100-C1

7/2	1LA7, 1MA7 · Frame sizes 56 M to 160 L 1LA5 · Frame sizes 180 M to 225 M
7/4	1LA9 · Frame sizes 56 to 200 L
7/6	1LA6, 1MA6 · Frame sizes 100 L to 160 L
7/8	1MA6 · Frame sizes 180 M to 315 L
7/10	1LG4 · Frame sizes 180 M to 315 L
7/12	1LG6 · Frame sizes 180 M to 315 L
7/14	1LA8 · Frame sizes 315 to 450 L
7/16	1MJ6, 1MJ7 · Frame sizes 71 M to 160 L
7/18	1MJ6 · Frame sizes 180 M to 315 M 1MJ8 · Frame sizes 315 M to 355
7/20	Flange dimensions Dimensions for combustion gas motors and 1MJ1 motors on request

Notes on the dimensions

■ Dimension drawings according to DIN EN 50 347 and IEC 60 072.

■ Fits

The shaft extensions specified in the dimension tables (DIN 748) and centering spigot diameters (DIN 42 948) are machined with the following fits:

Dimension designation	ISO fit DIN ISO 286-2	
D, DA	to 30	j6
	over 30 to 50	k6
	over 50	m6
N	to 250	j6
	over 250	h6
F, FA		h9

The drilled holes of couplings and belt pulleys should have an ISO fit of at least H7.

■ Dimensional tolerances

For the following dimensions, the permissible deviations are given below:

Dimension designation	Dimension	Permitted deviation
A, B	to 250	± 0.75
	over 250 to 500	± 1.0
	over 500 to 750	± 1.5
	over 750 to 1000	± 2.0
	over 1000	± 2.5
M	to 200	± 0.25
	over 200 to 500	± 0.5
	over 500	± 1.0
H	to 250	- 0.5
	over 250	- 1.0
E, EA		- 0.5

Keyways and featherkeys (dimensions GA, GC, F and FA) are made in compliance with DIN 6885 Part 1.

■ All dimension data is specified in mm.

Squirrel-cage motors

Dimensions

1LA7, 1MA7 · Frame sizes 56 M to 160 L
1LA5 · Frame sizes 180 M to 225 M

IM B 3

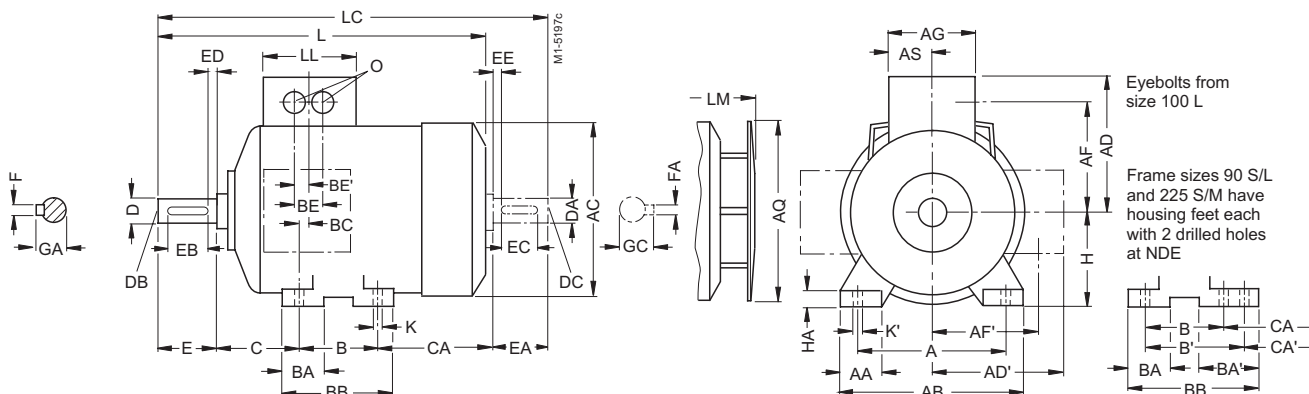

IM B 5 and IM V1 · For flange dimensions, see Page 7/20 (Z = Number of fixing holes)

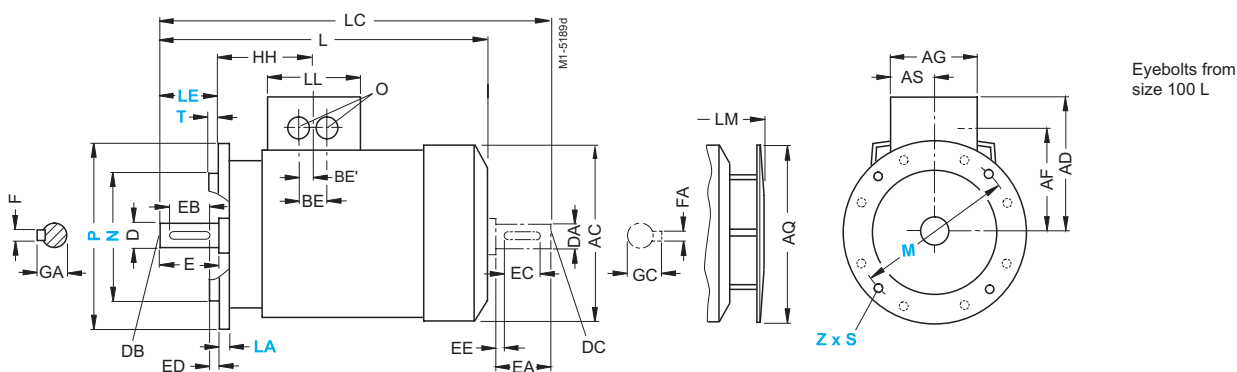

For motor			Dimension drawing according to IEC																					
Size	Type	No. of poles	A	AA	AB	AC ¹⁾	AD	AD'	AF	AF'	AG	AQ	AS	B	B'	BA	BA'	BB	BC	BE	BE'	C	CA	CA
56 M	1LA7 050 1MA7 053	2 to 4	90	25	110	116	101	101	78	78	74	-	37	71	-	28	-	87	34	32	18	36	53	-
63 M	060 063	2 to 6	100	27	120	124	101 (135)	101 (95)	78	78	74 (120)	124	37 (60)	80	-	28	-	96	30 (52.5)	32	18	40	66	-
71 M	070 073	2 to 8	112	27	132	145	111 (145)	111 (105)	88	88	74 (120)	124	37 (60)	90	-	27	-	106	18 (41.5)	32	18	45	83	-
80 M	080 083	2 to 8	125	30.5	150	163	120 (154)	120 (114)	97	97	75 (120)	124	37.5 (60)	100	-	32	-	118	14 (36)	32	18	50	94 (134 ⁴⁾)	-
90 S 90 L	090 096	2 to 8	140	30.5	165	180	128 (162)	128 (162)	105	105	75 (120)	170	37.5 (60)	100*	125 125*	33	54	143	23 (46)	32	18	56	143	118
100 L	106 107	2 to 8 4 and 8	160	42	196	203	135	163	78	123	120	170	60	140	-	47	-	176	39	42	21	63	125	-
112 M	113	2 to 8	190	46	226	227	148	176	91	136	120	170	60	140	-	47	-	176	32	42	21	70	141	-
132 S	130 131 2	2 to 8	216	53	256	267	167	194	107	154	140	250	70	140	-	49	-	180	39	42	21	89	162.5	-
132 M	133 134	4 to 8 6	216	53	256	267	167	194	107	154	140	250	70	178	-	49	-	218	39	42	21	89	124.5 162.5 ⁵⁾)	-
160 M	163 164	2 to 8 2 and 8	254	60	300	320	197	226	127	183	165	250	82.5	210	-	57	-	256	52.5	54	27	108	183	-
160 L	166	2 to 8	254	60	300	320	197	226	127	183	165	250	82.5	254	-	57	-	300	52.5	54	27	108	139 179 ⁶⁾)	-
180 M	1LA5 183	2 and 4	279	69.5	339	363	258	258	216	216	152	340	71	241	-	50	-	287	38	54	27	121	259	-
180 L	1LA5 186	4 to 8	279	69.5	339	363	258	258	216	216	152	340	71	279	-	50	-	325	38	54	27	121	221	-
200 L	1LA5 206 1LA5 207	2 and 6 2 to 8	318	83	388	402	305	305	252	252	260	340	96	305	-	58.5	-	355	45	85	42.5	133	239	-
225 S	1LA5 220	4 and 8	356	103	426	402	305	305	252	252	260	340	96	286*	311	58	83	361	36	85	42.5	149	248.5	-
225 M	1LA5 223	2 4 to 8	356	103	426	402	305	305	252	252	260	340	96	286	311*	58	83	361	36	85	42.5	149	-	223.5

■ The dimensions in brackets apply to 1MA7.

■ For 1LA in pole-changing version (6 or 9 terminals), the dimensions of the basic version apply.

* This dimension is assigned in EN 50347 to the frame size listed.

● The motors of frame size 56 M are non-ventilated.

1) Measured across the screw heads.

2) With a cast-on terminal housing, 4 knockout openings are provided for metric threads.

Squirrel-cage motors Dimensions

1LA7, 1MA7 · Frame sizes 56 M to 160 L
1LA5 · Frame sizes 180 M to 225 M

IM B 35 · For flange dimensions, see Page 7/20 (Z = Number of fixing holes)

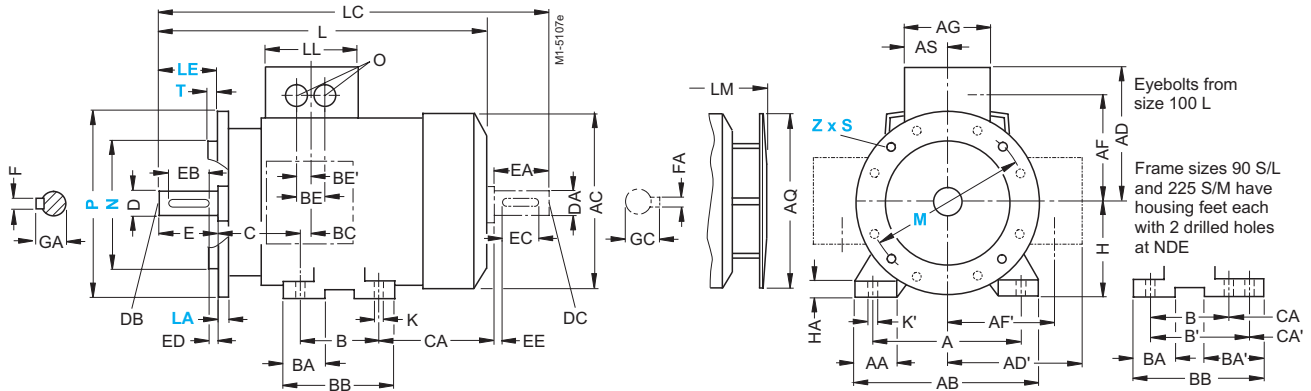

IM B 14 · For flange dimensions, see Page 7/20 (Z = Number of fixing holes)

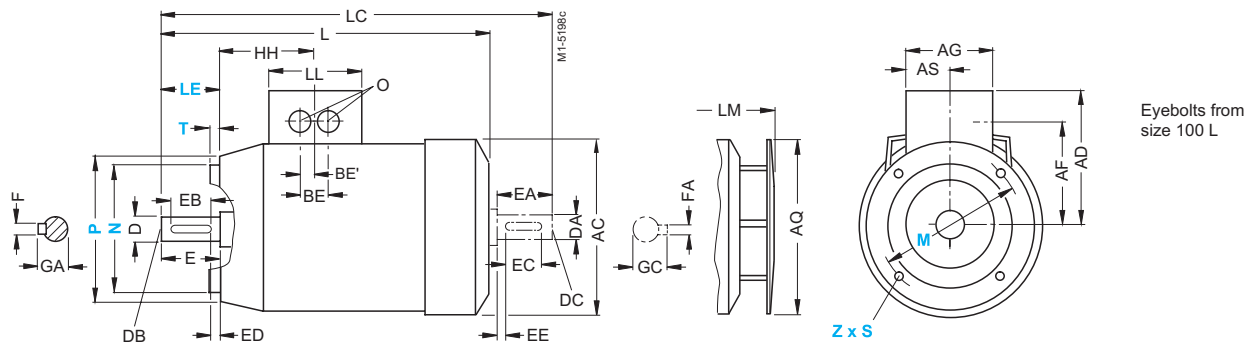

H	HA	HH	K	K'	L	LC	LL	LM	O	Drive-end shaft extension					Non-drive-end shaft extension								
										D	DB	E	EB	ED	F	GA	DA	DC	EA	EC	EE	FA	GC
56	6	69.5	5.8	9	169	200	74	-	1x M16 x 1.5 1x M25 x 1.5	9	M3	20	14	3	3	10.2	9	M3	20	14	3	3	10.2
63	7	69.5 (92.5)	7	10	202.5	232	74 (120)	231.5	1x M16 x 1.5 1x M25 x 1.5	11	M4	23	16	3.5	4	12.5	11	M4	23	16	3.5	4	12.5
71	7	63.5 (86.5)	7	10	240	278	74 (120)	268	1x M16 x 1.5 1x M25 x 1.5	14	M5	30	22	4	5	16	14	M5	30	22	4	5	16
80	8	63.5 (86)	9.5	13.5	273.5 308.5 ⁴⁾	324 364	75 (120)	299.5 334.5 ⁴⁾	1x M16 x 1.5 1x M25 x 1.5	19	M6	40	32	4	6	21.5	19	M6	40	32	4	6	21.5
90	10	79 (101.5)	10	14	331	389	75 (120)	382.5	1x M16 x 1.5 1x M25 x 1.5	24	M8	50	40	5	8	27	19	M6	40	32	4	6	21.5
100	12	102	12	16	372	438	120	423.5	2x M32 x 1.5 ²⁾	28	M10	60	50	5	8	31	24	M8	50	40	5	8	27
112	12	102	12	16	393	461	120	444.5	2x M32 x 1.5 ²⁾	28	M10	60	50	5	8	31	24	M8	50	40	5	8	27
132	15	128	12	16	452.5 ³⁾	551.5	140	505 ³⁾	2x M32 x 1.5 ²⁾	38	M12	80	70	5	10	41	38	M12	80	70	5	10	41
132	15	128	12	16	452.5 ³⁾ 490.5 ³⁾	551.5 589.5 ³⁾	140	505 ³⁾ 543 ³⁾	2x M32 x 1.5 ²⁾	38	M12	80	70	5	10	41	38	M12	80	70	5	10	41
160	18	160.5	15	19	588	721	165	640.5	2x M32 x 1.5 ²⁾	42	M16	110	90	10	12	45	42	M16	110	90	10	12	45
160	18	160.5	15	19	588 628 ⁶⁾	721 761 ⁶⁾	165	640.5 680.5 ⁶⁾	2x M32 x 1.5 ²⁾	42	M16	110	90	10	12	45	42	M16	110	90	10	12	45
180	18	159	15	19	712	841	132	793.5	2x M40 x 1.5	48	M16	110	100	5	14	51.5	48	M16	110	100	5	14	51.5
180	18	159	15	19	712	841	132	793.5	2x M40 x 1.5	48	M16	110	100	5	14	51.5	48	M16	110	100	5	14	51.5
200	24	178	19	25	768.5	897	192	850	2x M50 x 1.5	55	M20	110	100	5	16	59	55	M20	110	100	5	16	59
225	24	184.5	19	25	806	933.5	192	887.5	2x M50 x 1.5	60	M20	140	125	7.5	18	64	55	M20	110	100	5	16	59
225	24	184.5	19	25	776 806	903.5 933.5	192	857.5 887.5	2x M50 x 1.5	55 60	M20 M20	110 140	100 125	5 7.5	16 18	59 64	55	M20	110	100	5	16	59

3) In a low-noise version, the dimension L is 8 mm greater and the dimension LM is 11.5 mm greater.

4) For 1MA7 083-6.

5) For 1MA7 133-4.

6) For 1MA7 166-4 and 1MA7 166-6.

Squirrel-cage motors

Dimensions

1LA9 · Frame sizes 56 M to 200 L

IM B 3

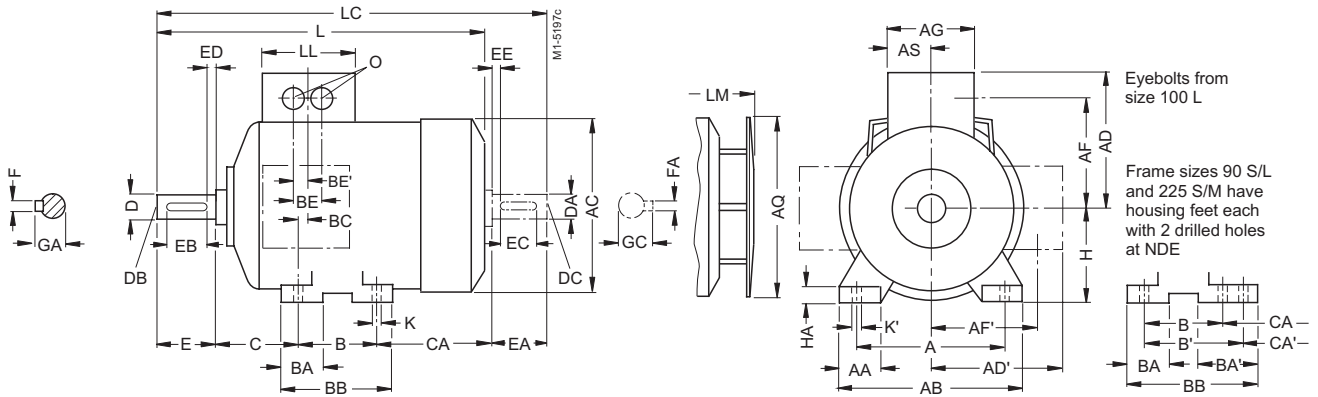

IM B 5 and IM V1 · For flange dimensions, see Page 7/20 (Z = Number of fixing holes)

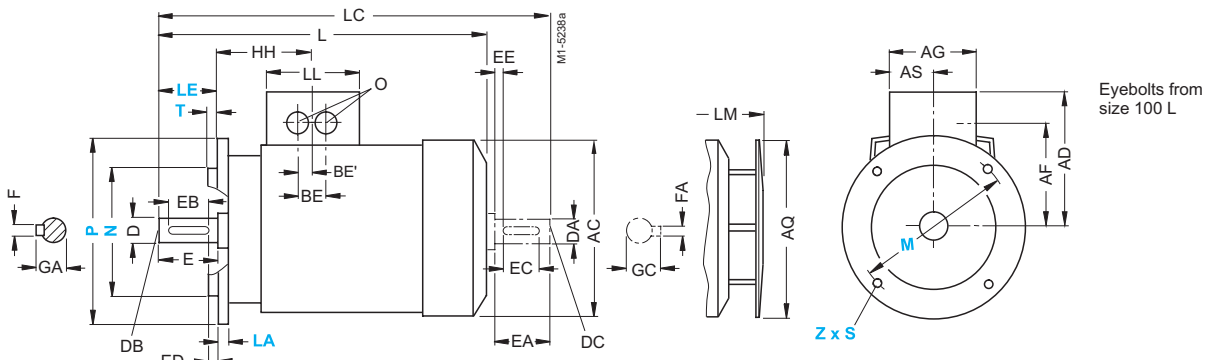

7

For motor			Dimension drawing according to IEC																						
Size	Type 1LA9 ...	No. of poles	A	AA	AB	AC ¹⁾	AD	AD'	AF	AF'	AG	AQ	AS	B	B'	BA	BA'	BB	BC	BE	BE'	C	CA	CA	
56 M	... 050 ... 053	2 and 4	90	25	110	116	101	101	78	78	74	-	37	71	-	28	-	87	34	32	18	36	53	-	
63 M	... 060 ... 063	2 and 4	100	27	120	124	101	101	78	78	74	124	37	80	-	28	-	96	30	32	18	40	66	-	
71 M	... 070 ... 073	2 and 4	112	30.5	132	145	111	111	88	88	74	124	37	90	-	27	-	106	18	32	18	45	83	-	
80 M	... 080 ... 083	2 and 4	125	30.5	150	163	120	120	97	97	75	124	37.5	100	-	32	-	118	14	32	18	50	94	-	
90 S	... 090	2 to 6	140	30.5	165	180	128	128	105	105	75	170	37.5	100*	125	33	54	143	23	32	18	56	143	118	
90 L	... 096-6K ... 096	2 and 6	140	30.5	165	180	128	128	105	105	75	170	37.5	100	125*	33	54	143	23	32	18	56	143	118	
100 L	... 106 ... 107	2 to 6 4	160	42	196	203	135	163	78	123	120	170	60	140	-	47	-	176	39	42	21	63	160	-	
112 M	... 113	2 to 6	190	46	226	227	148	176	91	136	120	170	60	140	-	47	-	176	32	42	21	70	179	-	
132 S	... 130 ... 131	2 and 4 2	216	53	256	267	167	194	107	154	140	250	70	140	-	49	-	180	39	42	21	89	162.5	-	
132 M	... 133 ... 133 ... 134	6 4 6	216	53	256	267	167	194	107	154	140	250	70	178	-	49	-	218	39	42	21	89	124.5	-	
160 M	... 163 ... 164	2 to 6 2	254	60	300	320	197	226	127	183	165	250	82.5	210	-	57	-	256	52.5	54	27	108	183	-	
160 L	... 166	2 to 6	254	60	300	320	197	226	127	183	165	250	82.5	254	-	57	-	300	52.5	54	27	108	179	-	
180 M	... 183	2 and 4	279	69.5	339	363	258	258	216	216	152	340	71	241	-	50	-	287	38	54	27	121	259	-	
180 L	... 186	4 and 6	279	69.5	339	363	258	258	216	216	152	340	71	279	-	50	-	325	38	54	27	121	221	-	
200 L	... 206 ... 207	2 and 6 2 to 6	318	83	388	402	305	305	252	252	260	340	96	305	-	58.5	-	355	45	85	42.5	133	239	-	

* This dimension is assigned in EN 50347 to the frame size listed.
 • The motors of frame size 56 M are non-ventilated.

1) Measured across the screw heads.
 2) With a cast-on terminal housing, 4 knockout openings are provided for metric threads.
 3) For 1LA9 096-6KA.
 4) For 1LA9 096-2 and 1LA9 096-4.
 5) For 1LA9 107-4KA.

Squirrel-cage motors Dimensions

1LA9 · Frame sizes 56 M to 200 L

IM B 35 · For flange dimensions, see Page 7/20 (Z = Number of fixing holes)

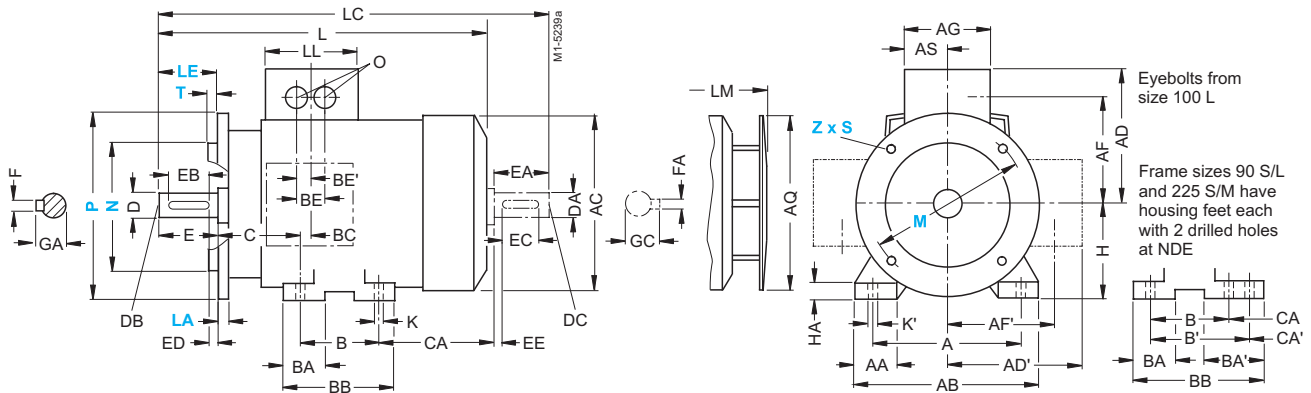

IM B 14 · For flange dimensions, see Page 7/20 (Z = Number of fixing holes)

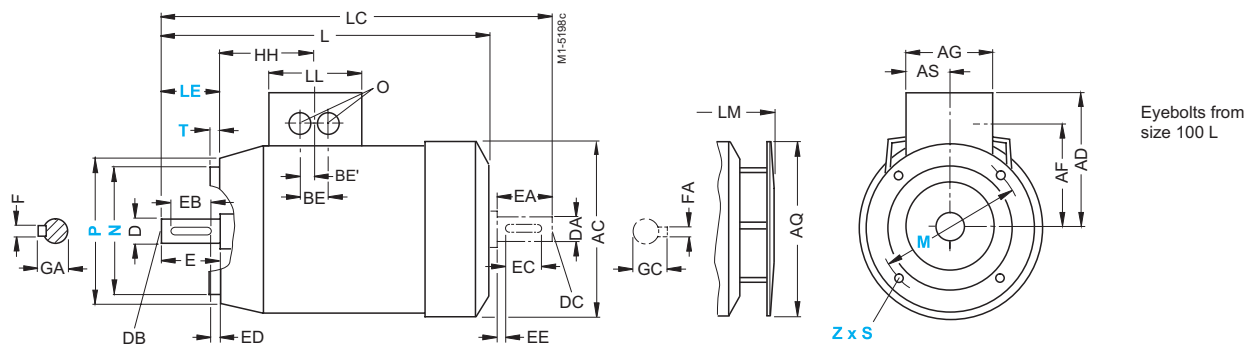

H	HA	HH	K	K'	L	LC	LL	LM	O	Drive-end shaft extension					Non-drive-end shaft extension								
										D	DB	E	EB	ED	F	GA	DA	DC	EA	EC	EE	FA	GC
56	6	69.5	5.8	9	169	200	74	-	1x M16 x 1.5 1x M25 x 1.5	9	M3	20	14	3	3	10.2	9	M3	20	14	3	3	10.2
63	7	69.5	7	10	202.5	232	74	231.5	1x M16 x 1.5	11	M4	23	16	3.5	4	12.5	11	M4	23	16	3.5	4	12.5
					228.5	258	257.5	1x M25 x 1.5															
71	7	63.5	7	10	240	278	74	268	1x M16 x 1.5 1x M25 x 1.5	14	M5	30	22	4	5	16	14	M5	30	22	4	5	16
80	8	63.5	9.5	13.5	273.5	324	75	299.5	1x M16 x 1.5	19	M6	40	32	4	6	21.5	19	M6	40	32	4	6	21.5
					308.5	364	334.5	1x M25 x 1.5															
90	10	79	10	14	331	389	75	382.5	1x M16 x 1.5	24	M8	50	40	5	8	27	19	M6	40	32	4	6	21.5
					376 ³⁾	434 ³⁾	427.5 ³⁾	1x M25 x 1.5															
100	12	102	12	16	407	473	120	458.5	2x M32 x 1.5 ²⁾	28	M10	60	50	5	8	31	24	M8	50	40	5	8	27
					442 ⁵⁾	508 ⁵⁾	493 ⁵⁾																
112	12	102	12	16	431	499	120	482.5	2x M32 x 1.5 ²⁾	28	M10	60	50	5	8	31	24	M8	50	40	5	8	27
132	15	128	12	16	452.5	551.5	140	505	2x M32 x 1.5 ²⁾	38	M12	80	70	5	10	41	38	M12	80	70	5	10	41
					490.5	589.5	543																
132	15	128	12	16	452.5	551.5	140	505	2x M32 x 1.5 ²⁾	38	M12	80	70	5	10	41	38	M12	80	70	5	10	41
160	18	160.5	15	19	588	721	165	640.5	2x M40 x 1.5 ²⁾	42	M16	110	90	10	12	45	42	M16	110	90	10	12	45
					628	761	680.5	2x M40 x 1.5 ²⁾															
180	18	159	15	19	712	841	132	793.5	2x M40 x 1.5	48	M16	110	100	5	14	51.5	48	M16	110	100	5	14	51.5
180	18	159	15	19	712	841	132	793.5	2x M40 x 1.5	48	M16	110	100	5	14	51.5	48	M16	110	100	5	14	51.5
200	24	178	19	25	768.5	897	192	850	2x M50 x 1.5	55	M20	110	100	5	16	59	55	M20	110	100	5	16	59

7

Squirrel-cage motors

Dimensions

1LA6/1PP6, sizes 100 to 160

IM B 3

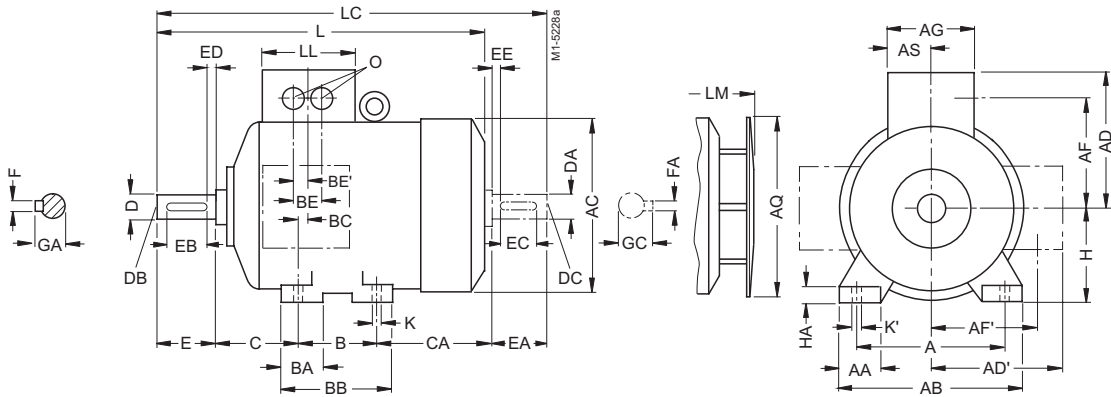

IM B 5 and IM V1 · For flange dimensions, see Page 7/20 (Z = Number of fixing holes)

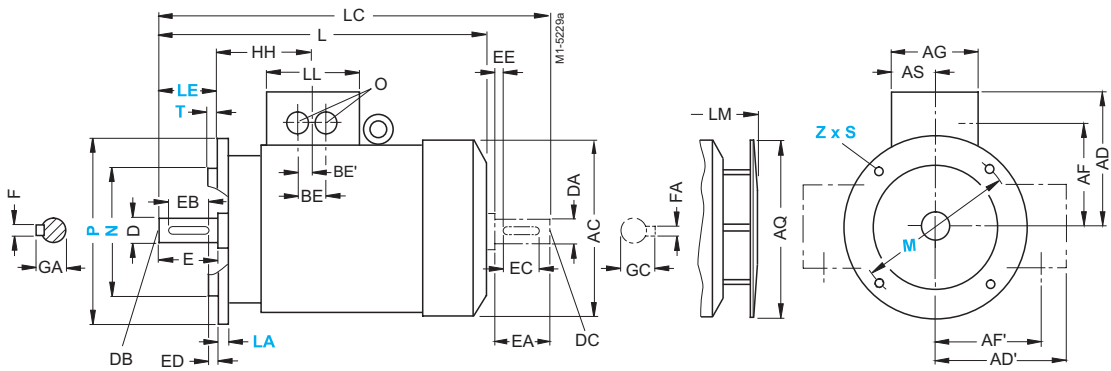

7

For motor			Dimension drawing according to IEC																				
Size	Type	No. of poles	A	AA	AB	AC ¹⁾	AD	AD'	AF	AF'	AG	AQ	AS	B	BA	BB	BC	BE	BE'	C	CA	H	HA
100 L	106	2 to 8	160	40	196	201	164	164	124	124	121	170	60.5	140	46	180	42	42	21	63	125	100	12
	107	4 and 8																					
112 M	113	2 to 8	190	42.5	226	225.5	178	178	138	138	121	170	60.5	140	46	180	34	42	21	70	141	112	15
132 S	130	2 to 8	216	50	256	265	194	194	154	154	141	250	70.5	140	47	180	42	42	21	89	162.5	132	17
	131	2																					
132 M	133	4 to 8	216	50	256	265	194	194	154	154	141	250	70.5	178	49	218	42	42	21	89	124.5	132	17
	134	6																					
160 M	163	2 to 8	254	60	300	320	226	226	183	183	166	250	83	210	63	256	52	54	27	108	183	160	18
	164	2 and 8																					
160 L	166	2 to 8	254	60	300	320	226	226	183	183	166	250	83	254	63	300	52	54	27	108	139	160	18

1) Measured across the screw heads.

Squirrel-cage motors Dimensions

1LA6/1PP6, sizes 100 to 160

IM B 35 · For flange dimensions, see Page 7/20 (Z = Number of fixing holes)

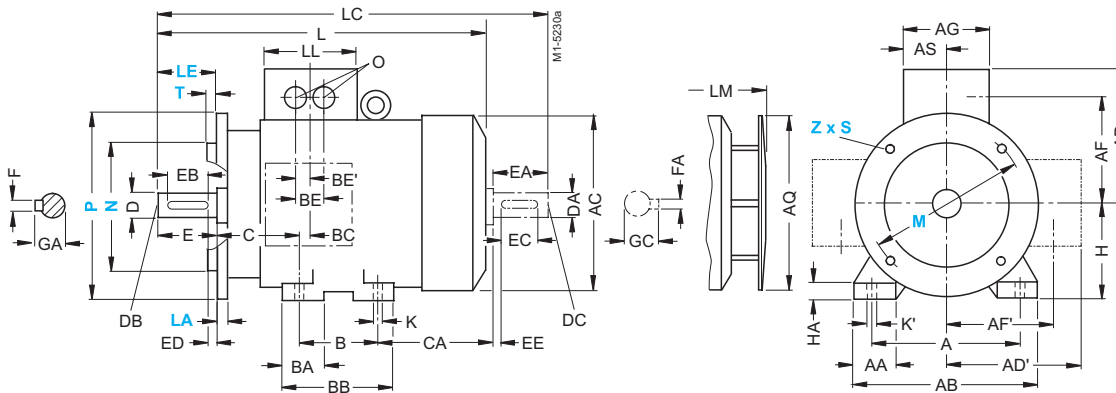

IM B 14 · For flange dimensions, see Page 7/20 (Z = Number of fixing holes)

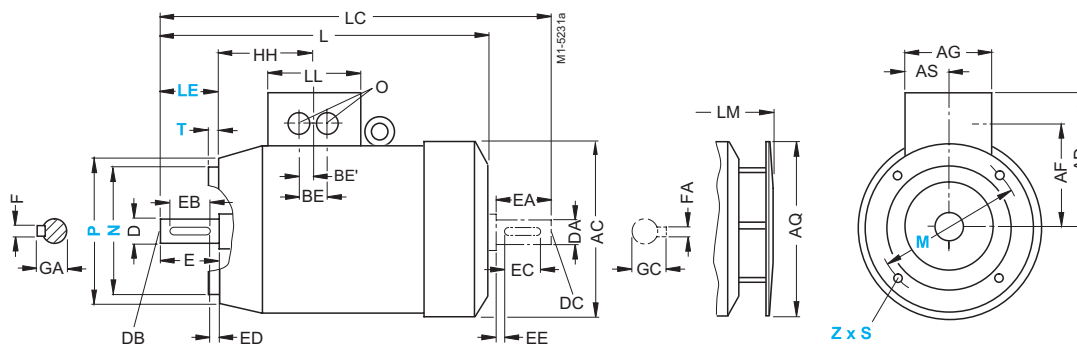

HH	K	K'	L	LC	LL	LM	O	Drive-end shaft extension					Non-drive-end shaft extension								
								D	DB	E	EB	ED	F	GA	DA	DC	EA	EC	EE	FA	GC
104.5	12	16	372	438	121	423.5	2x M32 x 1.5	28	M10	60	50	5	8	31	24	M8	50	40	5	8	27
104.5	12	16	393	461	121	444.5	2x M32 x 1.5	28	M10	60	50	5	8	31	24	M8	50	40	5	8	27
130.5	12	16	453.5	551.5	141	506	2x M32 x 1.5	38	M12	80	70	5	10	41	38	M12	80	70	5	10	41
130.5	12	16	453.5	551.5	141	506	2x M32 x 1.5	38	M12	80	70	5	10	41	38	M12	80	70	5	10	41
160	14.5	18	588	721	166	640.5	2 x M40 x 1.5	42	M16	110	90	10	12	45	42	M16	110	90	10	12	45
160	14.5	18	588	721	166	640.5	2 x M40 x 1.5	42	M16	110	90	10	12	45	42	M 16	110	90	10	12	45

Squirrel-cage motors

Dimensions

1LG6 · Frame sizes 180 M to 315 L

IM B 3

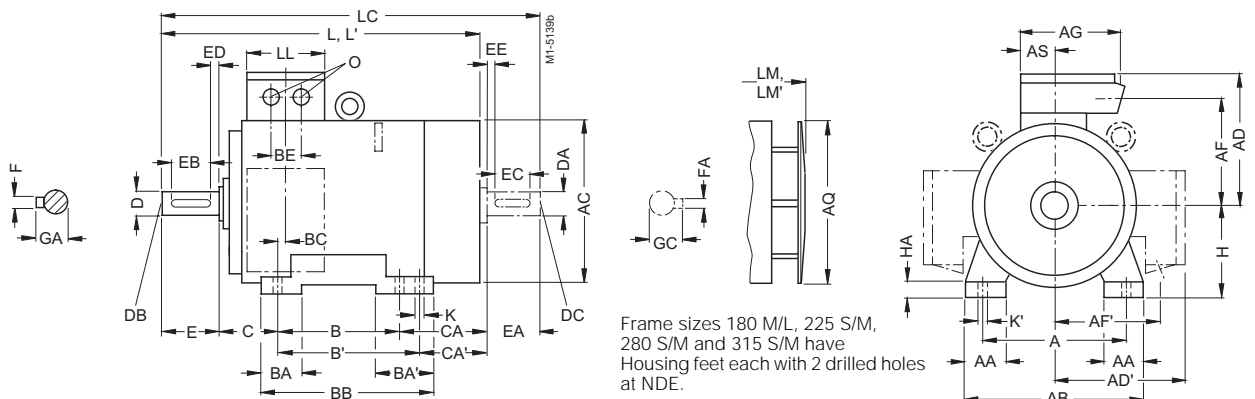

IM B 5 and IM V1 · For flange dimensions, see Page 7/20 (Z = Number of fixing holes)

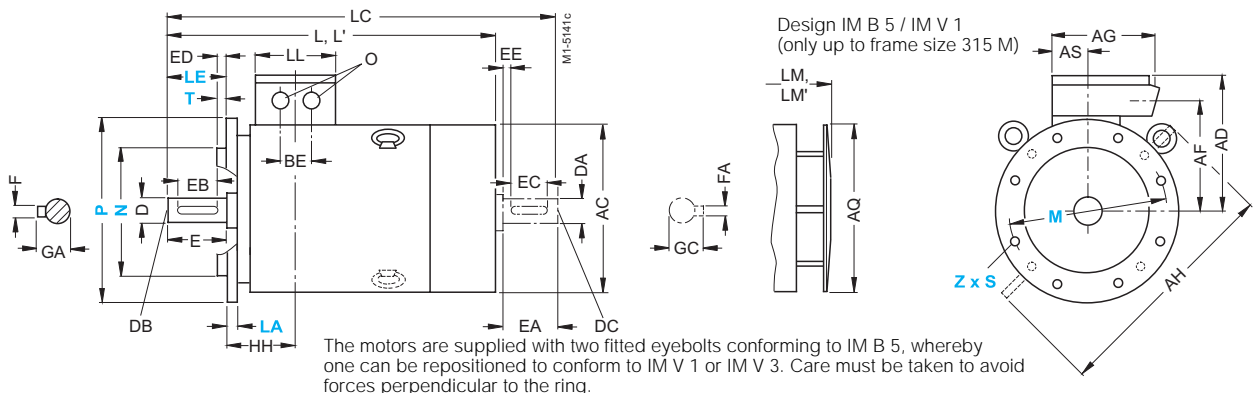

7

For motor			Dimension drawing according to IEC																					
Size	Type	No. of poles	A	AA	AB	AC ¹⁾	AD	AD'	AF	AF'	AG	AH	AQ	AS	B	B'	BA	BA'	BB	BC	BE	C	CA	CA'
180 M	1MA6 183	2 4	279	65	344	375	274	274	227	227	220	470	340	82	241*	279	70	108	319	35	75	121	259	-
180 L	186	4 to 8	279	65	344	375	274	274	227	227	220	470	340	82	241	279*	70	108	319	35	75	121	-	221
200 L	206	2 6	318	80	398	402	308	308	248	248	262	530	340	99	305	-	85	85	355	42	85	133	239	-
	207	2 4 to 8	318	80	398	402	308	308	248	248	262	530	340	99	305	-	85	85	355	42	85	133	239	-
225 S	220	4 and 8	356	80	436	442	339	339	269	269	264	580	425	100	286*	311	85	110	361	25	85	149	269	-
225 M	223	2 4 to 8	356	80	436	442	339	339	269	269	264	580	425	100	286	311*	85	110	361	25	85	149	-	244
250 M	253	2 4 to 8	406	100	506	505	427	427	333	333	338	645	470	120	349	-	100	100	409	39	95	168	283	-
280 S	280	2 4 to 8	457	100	557	555	452	452	358	358	338	700	525	120	368*	419	100	151	471	30	95	190	317	-
280 M	283	2 4 to 8	457	100	557	555	452	452	358	358	338	700	525	120	368	419*	100	151	471	30	95	190	-	266
315 S	310	2 4 to 8	508	120	628	620	515	515	395	395	405	805	590	134	406*	457	125	171	527	32	90	216	358	-
315 M	313	2 4 to 8	508	120	628	620	515	515	395	395	405	805	590	134	406	457*	125	171	527	32	90	216	-	307
315 L	316 317 318	2 4 to 8 6 and 8	508	120	628	620	515	515	395	395	405	805	590	134	508	-	120	120	578	32	90	216	396	-

■ Dimensions for 9-terminal box on request.

* This dimension is assigned in EN 50347 to the frame size listed.

1) Measured across the screw heads.

2) For version with low-noise fan.

3) In the low-noise version, a second shaft end and/or top-mounted sensor is not possible.

Squirrel-cage motors Dimensions

1LG6 · Frame sizes 180 M to 315 L

IM B 35 · For flange dimensions, see Page 7/20 (Z = Number of fixing holes)

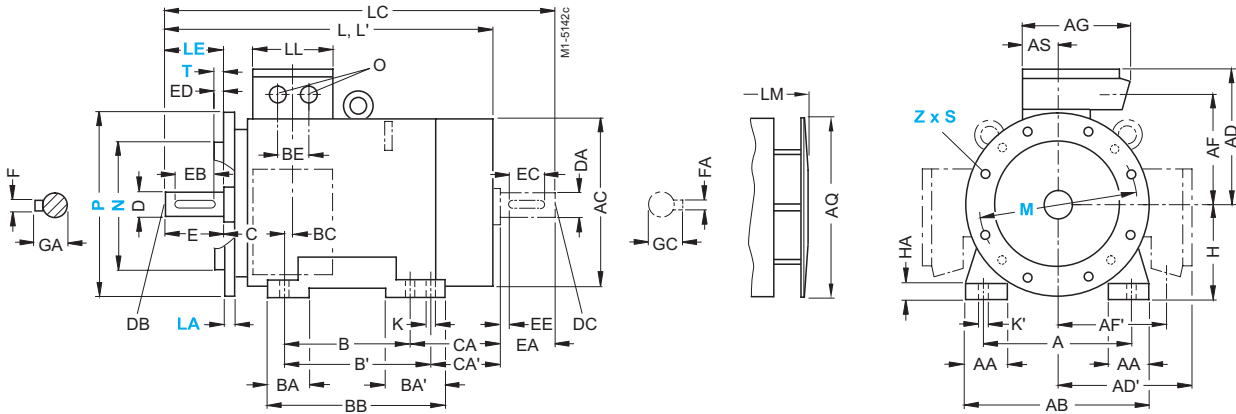

H	HA	HH	K	K'	L	L ²	LC ³	LL	LM	LM ²	O	Drive-end shaft extension					Non-drive-end shaft extension								
												D	DB	E	EB	ED	F	GA	DA	DC	EA	EC	EE	FA	GC
180	26	156	15	20	715	-	841	164	796.5	-	2 x M40 x 1.5	48	M 16	110	100	5	14	51.5	48	M 16	110	100	5	14	51.5
180	26	156	15	20	715	-	841	164	796.5	-	2 x M40 x 1.5	48	M 16	110	100	5	14	51.5	48	M 16	110	100	5	14	51.5
200	34	175	19	25	771.5	819.5	897	197	853	901	2 x M50 x 1.5	55	M 20	110	100	5	16	59	48	M 16	110	100	5	14	51.5
200	34	175	19	25	771.5	819.5	897	197	853	901	2 x M50 x 1.5	55	M 20	110	100	5	16	59	55	M 20	110	100	5	14	51.5
225	34	174	19	25	839	-	954	200	935	-	2 x M50 x 1.5	60	M 20	140	125	10	18	64	55	M 20	110	100	10	16	59
225	34	174	19	25	809	855	924	200	909	955	2 x M50 x 1.5	55	M 20	110	100	5	16	59	48	M 16	110	100	5	14	51.5
225	34	174	19	25	839	-	954	200	935	-	2 x M50 x 1.5	60	M 20	140	125	10	18	64	55	M 20	110	100	10	16	59
250	42	207	24	30	935	1010	1050	234	1035	1110	2 x M63 x 1.5	60	M 20	140	125	10	18	64	55	M 20	110	100	5	16	59
250	42	207	24	30	935	1010	1050	234	1035	1110	2 x M63 x 1.5	65	M 20	140	125	10	18	69	60	M 20	140	125	10	18	64
280	42	220	24	30	1010	1080	1155	234	1120	1230	2 x M63 x 1.5	65	M 20	140	125	10	18	69	60	M 20	140	125	10	18	64
280	42	220	24	30	1010	1080	1155	234	1120	1230	2 x M63 x 1.5	75	M 20	140	125	10	18	79.5	65	M 20	140	125	10	18	69
280	42	220	24	30	1010	1080	1155	234	1120	1230	2 x M63 x 1.5	75	M 20	140	125	10	18	79.5	65	M 20	140	125	10	18	69
315	52	248	28	35	1114	1185	1260	266	1224	1295	2 x M63 x 1.5	65	M 20	140	125	10	18	69	60	M 20	140	125	10	18	64
315	52	248	28	35	1114	1185	1260	266	1224	1295	2 x M63 x 1.5	80	M 20	140	125	10	18	85	70	M 20	140	125	10	18	74.5
315	52	248	28	35	1114	1185	1260	266	1224	1295	2 x M63 x 1.5	80	M 20	140	125	10	18	85	70	M 20	140	125	10	18	74.5
315	52	248	28	35	1254	1325	1400	266	1364	1435	2 x M63 x 1.5	65	M 20	140	125	10	18	69	60	M 20	140	125	10	18	64
315	52	248	28	35	1284	-	1430	266	1394	-	2 x M63 x 1.5	80	M 20	140	125	10	18	85	70	M 20	140	125	10	18	74.5
315	52	248	28	35	1284	-	1430	266	1394	-	2 x M63 x 1.5	80	M 20	140	125	10	18	85	70	M 20	140	125	10	18	74.5

Squirrel-cage motors

Dimensions

1MA6 · Frame sizes 180 M to 315 L

IM B 3

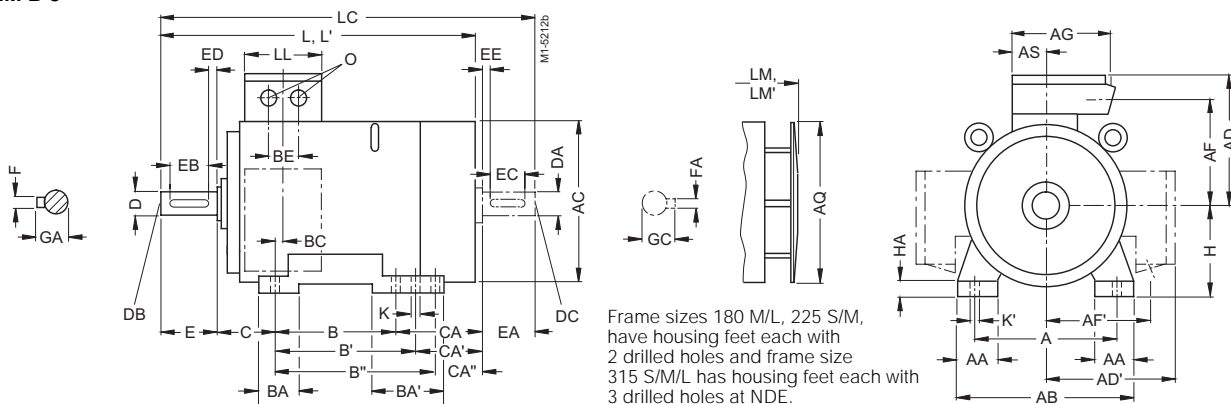

IM B 5 and IM V1 · For flange dimensions, see Page 7/20 (Z = Number of fixing holes)

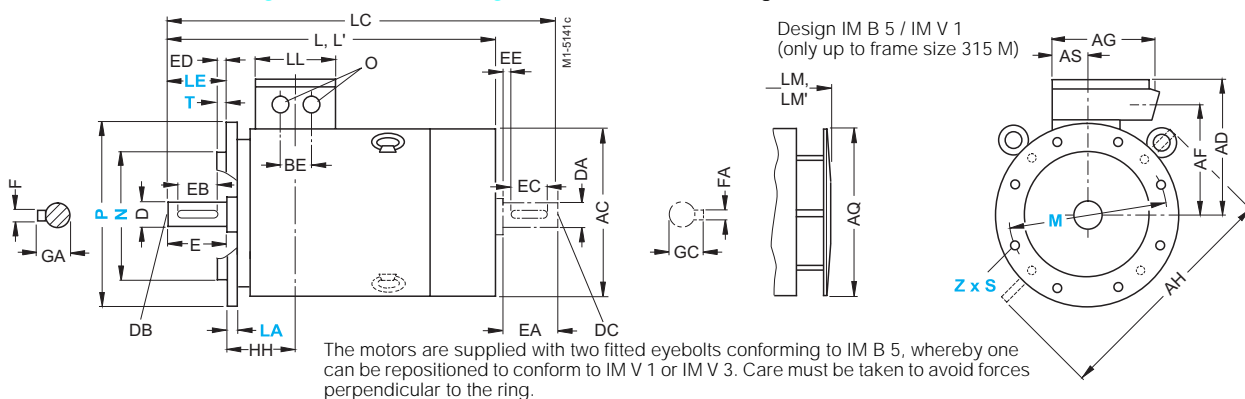

For motor			Dimension drawing according to IEC																							
Size	Type	No. of poles	A	AA	AB	AC ¹⁾	AD	AD'	AF	AF'	AG	AH	AQ	AS	B	B'	B''	BA	BA'	BB	BC	BE	C	CA	CA	
180 M	1LG4	2 and 4	279	65	339	363	262	262	218	218	152	452	340	71	241*	279	-	70	111	328	36	54	121	202*	164	
180 L		4 to 8	279	65	339	363	262	262	218	218	152	452	340	71	241	279*	-	70	111	328	36	54	121	202	164*	
		2 to 8	279	65	339	363	262	262	218	218	152	452	340	71	241	279*	-	70	111	328	36	54	121	253	215*	
200 L		2 and 6	318	70	378	402	300	300	247	247	260	486	340	96	305	-	-	80	80	355	63	85	133	177	-	
		2 to 8	318	70	378	402	300	300	247	247	260	486	340	96	305	-	-	80	80	355	63	85	133	177	-	
		2 and 6	318	70	378	402	300	300	247	247	260	486	340	96	305	-	-	80	80	355	63	85	133	234	-	
		4 and 8																						177		
225 S		4 and 8	356	80	436	442	325	325	272	272	260	556	425	96	286*	311	-	85	110	361	47	85	149	218*	193	
225 M		2	356	80	436	442	325	325	272	272	260	556	425	96	286	311*	-	85	110	361	47	85	149	218	193*	
		4 to 8																								
		2	356	80	436	442	325	325	272	272	260	556	425	96	286	311*	-	85	110	361	47	85	149	278	253*	
		4 to 8																								
250 M		2	406	100	490	495	392	392	308	308	300	620	470	117	349	-	-	100	100	409	69	110	168	235	-	
		4 to 8																								
		2	406	100	490	495	392	392	308	308	300	620	470	117	349	-	-	100	100	409	69	110	168	235	-	
		4																						305	-	
		6 and 8																						235	-	
280 S		2	457	100	540	555	432	432	348	348	300	672	525	118	368*	419	-	100	151	479	62	110	190	267*	216	
		4 to 8																								
280 M		2	457	100	540	555	432	432	348	348	300	672	525	118	368	419*	-	100	151	479	62	110	190	267	216*	
		4 to 8																								
		2	457	100	540	555	432	432	348	348	300	672	525	118	368	419*	-	100	151	479	62	110	190	377	326*	
		4																								
		6 and 8																							267	216*
315 S		2	508	120	610	610	495	495	406	406	379	780	590	154	406*	457	-	125	176	527	69	110	216	315*	264	
		4 to 8																								
315 M		2	508	120	610	610	495	495	406	406	379	780	590	154	406	457*	-	125	176	527	69	110	216	315	264*	
		4 to 8																								
315 L ⁴⁾		2	508	120	610	610	495	495	406	406	379	780	590	154	457	508*	-	125	176	578	69	110	216	424	373*	
		4 to 8																								
		8																								
		6	508	120	610	610	495	495	406	406	379	780	590	154	406	457	508*	155	250	666	69	110	216	615	564	

* This dimension is assigned in EN 50347 to the frame size listed.

1) Measured across the screw heads.

2) In version with low-noise fan for 2-pole motors.

3) In the low-noise version, a second shaft end and/or top-mounted sensor is not possible.

Squirrel-cage motors Dimensions

1MA6 · Frame sizes 180 M to 315 L

IM B 35 · For flange dimensions, see Page 7/20 (Z = Number of fixing holes)

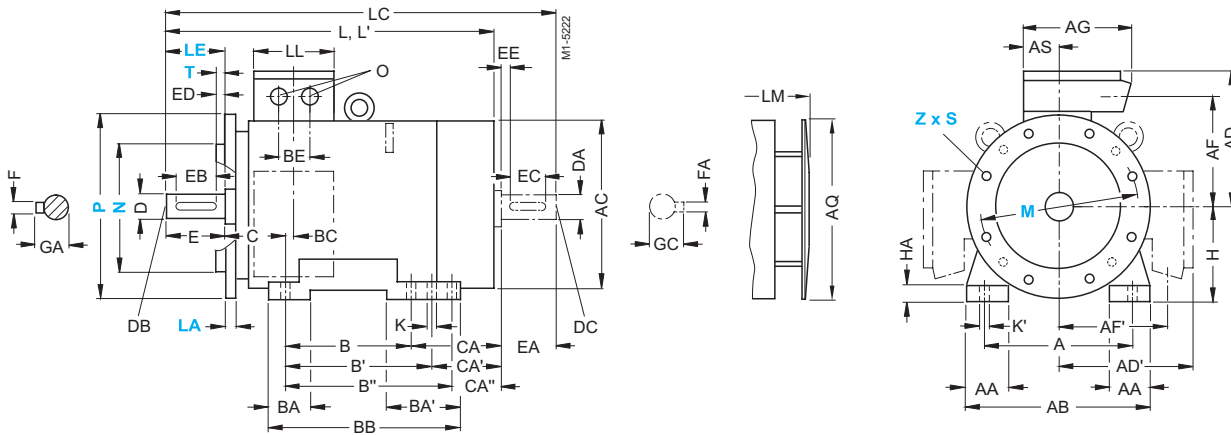

CA ⁴⁾	H	HA	HH	K	K'	L	L ²⁾	LC ³⁾	LL	LM	LM ²⁾	O	Drive-end shaft extension					Non-drive-end shaft extension								
													D	DB	E	EB	ED	F	GA	DA	DC	EA	EC	EE	FA	GC
180	20	157	15	19	668.5	668.5	784	132	758.5	758.5	2 x M40 x 1.5	48	M 16	110	100	5	14	51.5	48	M 16	110	100	5	14	51.5	
180	20	157	15	19	668.5	668.5	784	132	758.5	758.5	2 x M40 x 1.5	48	M 16	110	100	5	14	51.5	48	M 16	110	100	5	14	51.5	
180	20	157	15	19	719.5	719.5	835	132	809.5	809.5	2 x M40 x 1.5	48	M 16	110	100	5	14	51.5	48	M 16	110	100	5	14	51.5	
200	25	196	19	25	720	754	835	192	810	844	2 x M50 x 1.5	55	M 20	110	100	5	16	59	55	M 20	110	100	5	16	59	
200	25	196	19	25	720	754	835	192	810	844	2 x M50 x 1.5	55	M 20	110	100	5	16	59	55	M 20	110	100	5	16	59	
200	25	196	19	25	777	811	892	192	867	901	2 x M50 x 1.5	55	M 20	110	100	5	16	59	55	M 20	110	100	5	16	59	
					720	835	835	192	810	844	2 x M50 x 1.5	55	M 20	110	100	5	16	59	55	M 20	110	100	5	16	59	
225	34	196	19	25	789	903	192	889	889	953	2 x M50 x 1.5	60	M 20	140	125	10	18	64	55	M 20	110	100	5	16	59	
225	34	196	19	25	759	793	873	192	859	893	2 x M50 x 1.5	55	M 20	110	100	5	16	59	48	M 16	110	100	5	14	51.5	
					789	903	889	192	889	953	2 x M50 x 1.5	60	M 20	140	125	10	18	64	55	M 20	110	100	5	16	59	
225	34	196	19	25	819	853	933	192	919	953	2 x M50 x 1.5	55	M 20	110	100	5	16	59	48	M 16	110	100	5	14	51.5	
					849	963	949	192	919	953	2 x M50 x 1.5	60	M 20	140	125	10	18	64	55	M 20	110	100	5	16	59	
250	40	237	24	30	887	924	1002	236	987	1024	2 x M63 x 1.5	60	M 20	140	125	10	18	64	55	M 20	110	100	5	16	59	
					887	924	1032	236	987	1024	2 x M63 x 1.5	65	M 20	140	125	10	18	69	60	M 20	140	125	10	18	64	
250	40	237	24	30	887	924	1002	236	987	1024	2 x M63 x 1.5	60	M 20	140	125	10	18	64	55	M 20	110	100	5	16	59	
					957	1102	1057	236	987	1024	2 x M63 x 1.5	65	M 20	140	125	10	18	69	60	M 20	140	125	10	18	64	
					887	1032	987	236	987	1024	2 x M63 x 1.5	65	M 20	140	125	10	18	69	60	M 20	140	125	10	18	64	
280	40	252	24	30	960	998	1105	236	1070	1108	2 x M63 x 1.5	65	M 20	140	125	10	18	69	60	M 20	140	125	10	18	64	
					960	998	1105	236	1070	1108	2 x M63 x 1.5	75	M 20	140	125	10	20	79.5	65	M 20	140	125	10	18	69	
280	40	252	24	30	960	998	1105	236	1070	1108	2 x M63 x 1.5	65	M 20	140	125	10	18	69	60	M 20	140	125	10	18	64	
					960	998	1105	236	1070	1108	2 x M63 x 1.5	75	M 20	140	125	10	20	79.5	65	M 20	140	125	10	18	69	
280	40	252	24	30	1070	1108	1215	236	1180	1218	2 x M63 x 1.5	65	M 20	140	125	10	18	69	60	M 20	140	125	10	18	64	
					960	1108	1105	236	1070	1108	2 x M63 x 1.5	75	M 20	140	125	10	20	79.5	65	M 20	140	125	10	18	69	
					960	1108	1105	236	1070	1108	2 x M63 x 1.5	75	M 20	140	125	10	20	79.5	65	M 20	140	125	10	18	69	
315	50	285	28	35	1072	1142	1217	307	1182	1252	2 x M63 x 1.5	65	M 20	140	125	10	18	69	60	M 20	140	125	10	18	64	
					1102	1247	1212	307	1182	1252	2 x M63 x 1.5	80	M 20	170	140	10	22	85	70	M 20	140	125	10	20	74.5	
315	50	285	28	35	1072	1142	1217	307	1182	1252	2 x M63 x 1.5	65	M 20	140	125	10	18	69	60	M 20	140	125	10	18	64	
					1102	1247	1212	307	1182	1252	2 x M63 x 1.5	80	M 20	170	140	10	22	85	70	M 20	140	125	10	20	74.5	
315	50	285	28	35	1232	1302	1377	307	1342	1412	2 x M63 x 1.5	65	M 20	140	125	10	18	69	60	M 20	140	125	10	18	64	
					1262	1407	1372	307	1342	1412	2 x M63 x 1.5	80	M 20	170	140	10	22	85	70	M 20	140	125	10	20	74.5	
					1262	1407	1372	307	1342	1412	2 x M63 x 1.5	80	M 20	170	140	10	22	85	70	M 20	140	125	10	20	74.5	
513*	315	30	285	28	35	1402		1547	307	1512		2 x M63 x 1.5	80	M 20	170	140	10	22	85	70	M 20	140	125	10	20	74.5

4) For terminal box system order codes (K09, K10, K11), screwed feet with foot dimensions

BB = 666 mm only (see "Technical Information", "Eyebolts").

Squirrel-cage motors Dimensions

1MA6 · Frame sizes 180 M to 315 L

IM B 35 · For flange dimensions, see Page 7/20 (Z = Number of fixing holes)

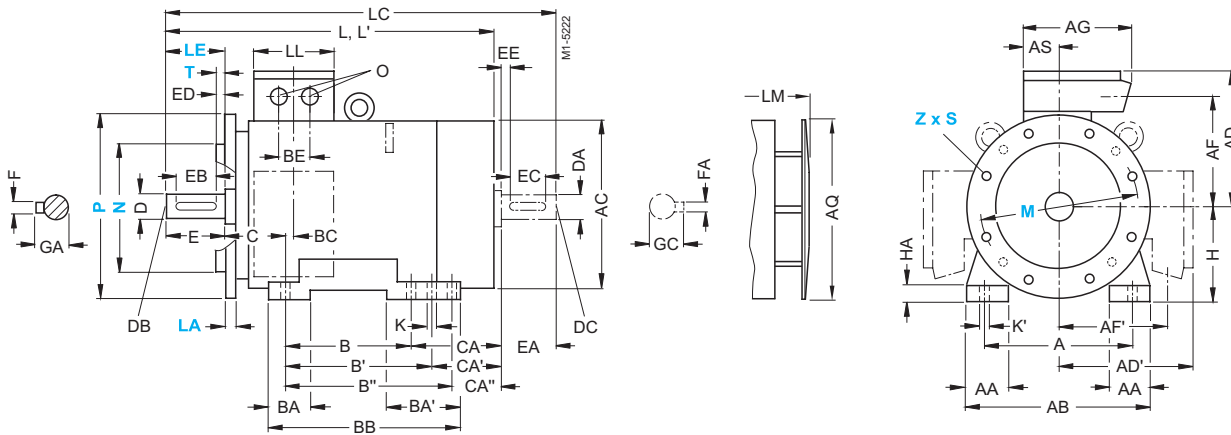

CA''	H	HA	HH	K	K'	L	L ²⁾	LC ³⁾	LL	LM	LM ²⁾	O	Drive-end shaft extension					Non-drive-end shaft extension					
													D	DB	E	EB	ED	F	GA	DA	DC	EA	EC
180	20	157	15	19	719.5	835	132	809.5	2 x M40 x 1.5	48	M 16	110	100	5	14	51.5	48	M 16	110	100	5	14	51.5
180	20	157	15	19	719.5	835	132	809.5	2 x M40 x 1.5	48	M 16	110	100	5	14	51.5	48	M 16	110	100	5	14	51.5
200	25	196	19	25	756	835	192	846	2 x M50 x 1.5	55	M 20	110	100	5	16	59	55	M 20	110	100	5	16	59
200	25	196	19	25	756	835	192	846	2 x M50 x 1.5	55	M 20	110	100	5	16	59	55	M 20	110	100	5	16	59
225	34	196	19	25	789	903	192	889	2 x M50 x 1.5	60	M 20	140	125	10	18	64	55	M 20	110	100	5	16	59
225	34	196	19	25	819	933	192	919	2 x M50 x 1.5	55	M 20	110	100	5	16	59	48	M 16	110	100	5	14	51.5
					849	963		949		60	M 20	140	125	10	18	64	55	M 20	110	100	5	16	59
225	34	196	19	25	869	983	192	969	2 x M50 x 1.5	55	M 20	110	100	5	16	59	48	M 16	110	100	5	14	51.5
					900	1013		1000		60	M 20	140	125	10	18	64	55	M 20	110	100	5	16	59
250	40	237	24	30	887	1002	236	987	2 x M63 x 1.5	60	M 20	140	125	10	18	64	55	M 20	110	100	5	16	59
					957	1102		1057		65	M 20	140	125	10	18	69	60	M 20	140	125	10	18	64
					887	1032		987		65	M 20	140	125	10	18	69	60	M 20	140	125	10	18	64
250	40	237	24	30	957	1102	236	1057	2 x M63 x 1.5	60	M 20	140	125	10	18	64	55	M 20	110	100	5	16	59
										65	M 20	140	125	10	18	69	60	M 20	140	125	10	18	64
280	40	252	24	30	960	1105	236	1070	2 x M63 x 1.5	65	M 20	140	125	10	18	69	60	M 20	140	125	10	18	64
										75	M 20	140	125	10	20	79.5	65	M 20	140	125	10	18	69
280	40	252	24	30	1070	1215	236	1180	2 x M63 x 1.5	65	M 20	140	125	10	18	69	60	M 20	140	125	10	18	64
										75	M 20	140	125	10	20	79.5	65	M 20	140	125	10	18	69
					960	1105		1070		75	M 20	140	125	10	20	79.5	65	M 20	140	125	10	18	69
280	40	252	24	30	1070	1215	236	1180	2 x M63 x 1.5	65	M 20	140	125	10	18	69	60	M 20	140	125	10	18	64
										75	M 20	140	125	10	20	79.5	65	M 20	140	125	10	18	69
315	50	285	28	35	1072	1217	307	1182	2 x M63 x 1.5	65	M 20	140	125	10	18	69	60	M 20	140	125	10	18	64
					1102	1247		1212		80	M 20	170	140	10	22	85	70	M 20	140	125	10	20	74.5
315	50	285	28	35	1102	1247	307	1212	2 x M63 x 1.5	80	M 20	170	140	10	22	85	70	M 20	140	125	10	20	74.5
315	50	285	28	35	1232	1377	307	1342	2 x M63 x 1.5	65	M 20	140	125	10	18	69	60	M 20	140	125	10	18	64
					1262	1407		1372		80	M 20	170	140	10	22	85	70	M 20	140	125	10	20	74.5
315	50	285	28	35	1232	1377	307	1342	2 x M63 x 1.5	65	M 20	140	125	10	18	69	60	M 20	140	125	10	18	64
					1262	1407		1372		80	M 20	170	140	10	22	85	70	M 20	140	125	10	20	74.5
										80	M 20	170	140	10	22	85	70	M 20	140	125	10	20	74.5

4) For terminal box system order codes (K09, K10, K11), screwed feet with foot dimensions

BB = 666 mm only (see "Technical Information", "Eyebolts").

Squirrel-cage motors

Dimensions

1LA8 · Frame sizes 315 to 450 L

IM B 3

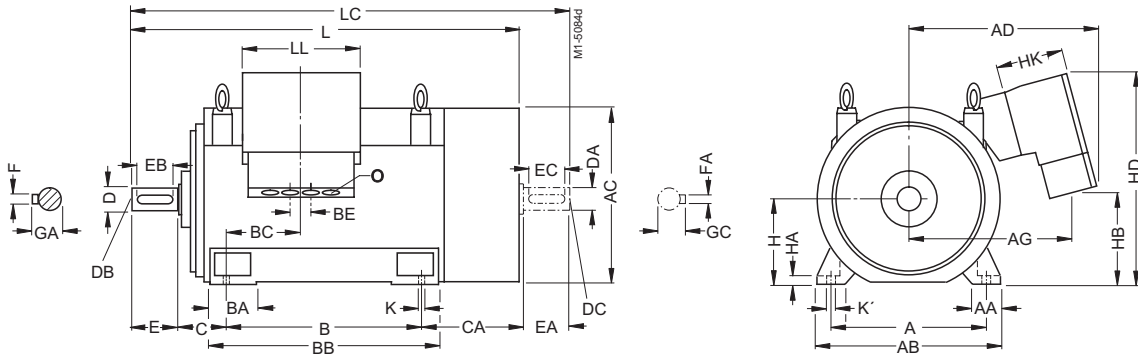

IM V1 · For flange dimensions, see Page 7/20 (Z = Number of fixing holes)

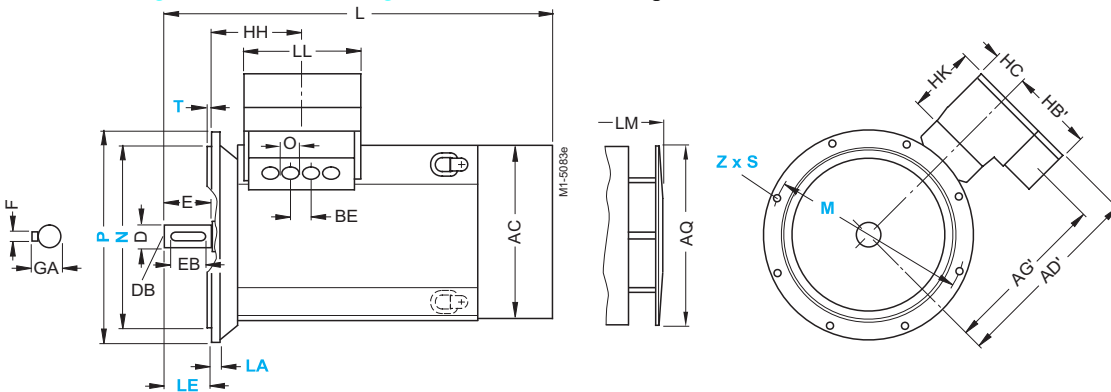

For motor		Dimension drawing according to IEC																		
Size	Type 1LA8...	No. of poles	A	AA	AB	AC ¹⁾	AD	AD'	AG	AG'	AQ	B	BA	BB	BC	BE	C	CA	H	HA
315	... 315	2	560	120	680	710	570	582	473	481	670	630	180	780	195	110	180	435	315	28
	... 317	4 to 8															180			
	... 31...	4 to 8 ²⁾															200			
355	... 353	2	630	150	780	790	710	730	585	600	750	800	220	980	185	135	200	470	355	35
	... 355	4 to 8															200			
	... 35...	4 to 8 ²⁾															224			
400	... 403	2	710	150	860	880	865	930	775	795	850	900	220	1080	186	100	224	506	400	35
	... 405	4 to 8																		
	... 407																			
450	... 453	2 ³⁾	800	180	980	970	900	980	810	845	950	1000	260	1220	170	100	250	540	450	42
	... 455	4 to 8																		
	... 457																			

Terminal box position

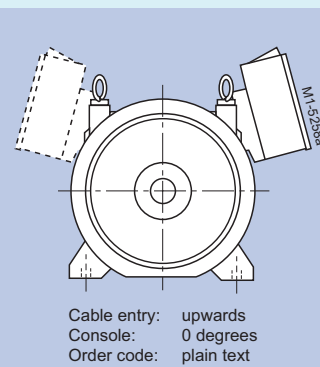
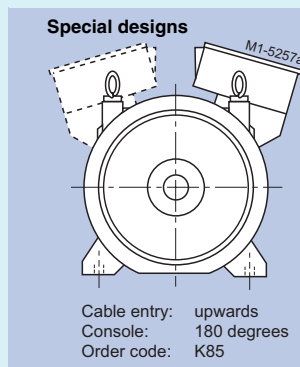
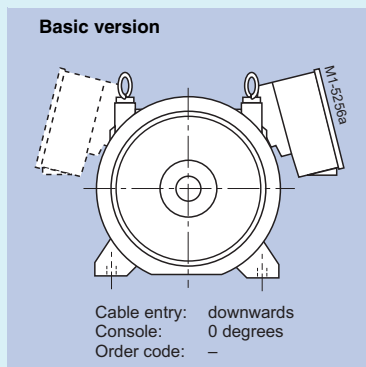

1) Measured across the screw heads (not in the flattened area of the fan cowl).

2) With bearing for increased lateral forces.

3) Only for 50 Hz.

Squirrel-cage motors Dimensions

1LA8 · Frame sizes 315 to 450 L

IM B 35 · For flange dimensions, see Page 7/20 (Z = Number of fixing holes)

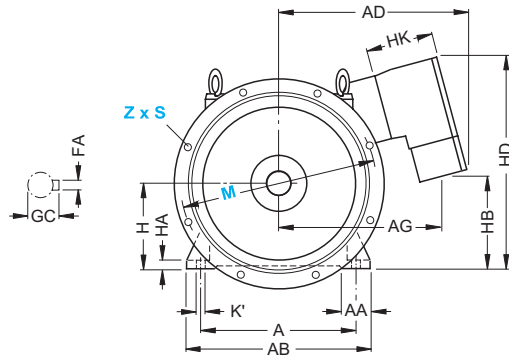
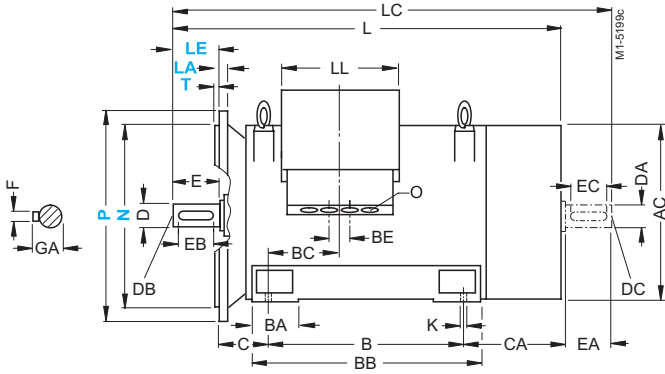

HB	HB'	HD	HK	K	K'	L	LC	LL	LM	O	Drive-end shaft extension					Non-drive-end shaft extension						
											D	DB	E	EB	F	GA	DA	DC	EA	EC	FA	GC
360	290	825	170	26	33	1370	1495	307	1500	M 63 x 1.5	65	M 20	140	125	18	69	50	M 16	110	100	14	53.5
											85	M 20	170	140	22	90	70	M 20	140	125	20	74.5
											95	M 24	170	140	25	100	70	M 20	140	125	20	74.5
400	285	905	229	33	40	1595	1750	330	1735	M 72 x 2	75	20 S	140	125	20	79.5	60	M 20	140	125	18	64
											95	24 M	170	140	25	100	80		170	140	22	85
											100	24 M	210	180	28	106	80	M 20	170	140	22	85
440	400	1020	320	33	40	1785	1940	550	1935	Ø 80	80	M 20	170	140	22	85	70	M 20	140	125	20	74.5
											110	M 24	210	180	28	116	90	M 24	170	140	25	95
525	400	1110	320	39	47	1945	2100	550	2105	Ø 80	90	M 24	170	140	25	95	75	M 20	140	125	20	79.5
											120		210	180	32	127	100	M 24	210	180	28	106

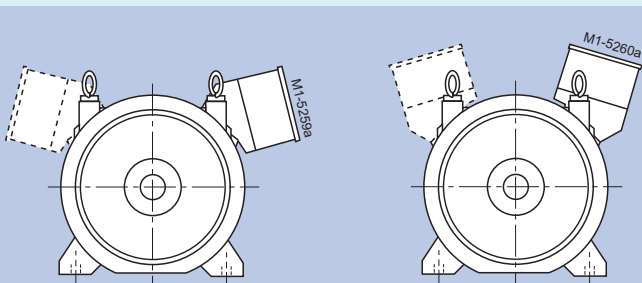

Cable entry: DE / NDE
Console: 0 degrees
Order code: K83/K84

Cable entry: DE / NDE
Console: 180 degrees
Order code: plain text

Squirrel-cage motors

Dimensions

1MA6 · Frame sizes 71 M to 160 L

IM B 3

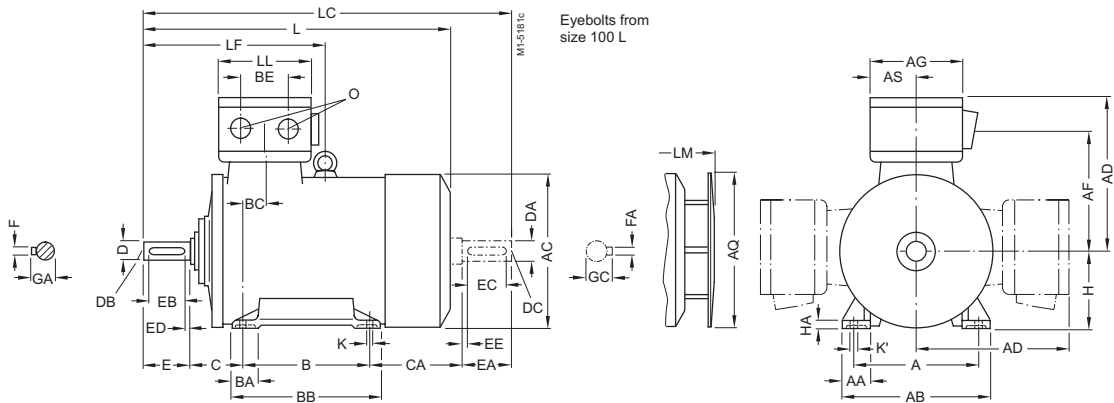

IM B5 and IM V1 · For flange dimensions, see Page 7/20 (Z = Number of fixing holes)

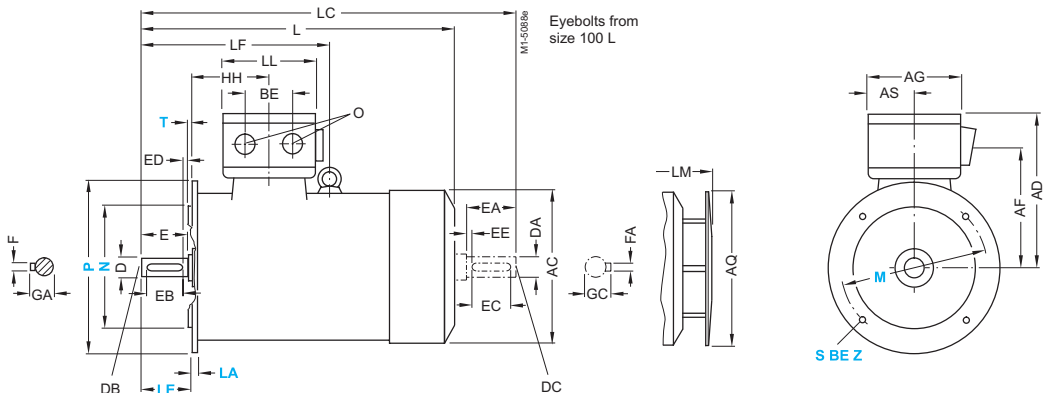

For motor			Dimension drawing according to IEC																					
Size	Type 1MJ6 ...	No. of poles	A	AA	AB	AC ¹⁾	AD	AF	AG	AQ	AS	B	BA	BB	BC	BE	C	CA	H	HA	HH	K	K'	L
71 M	... 070 ... 073	2 and 4 2 to 6	112	34	140	148.5	201 ²⁾	162	152	124	71	90	30	110	58	54	45	144	71	8	103	7	10	299
80 M	... 080 ... 083	2 to 6 2 to 6	125	36	160	165.5	209 ²⁾	170	152	125	71	100	35	125	44	54	50	156	80	10	93.5	9.5	13.5	336
90 L	... 096 ... 097	2 to 8 2 to 8	140	37	168	183	218	177	162	170	81	125	35	156	54	54	56	177	90	13	109.5	10	14	383
100 L	... 106 ... 107	2 to 8 4 and 8	160	45	196	202.5	223	182	162	170	81	140	45	176	50	54	63	185	100	14	112.5	12	16	426
112 M	... 113	2 to 8	190	50	226	228.5	238	197	162	170	81	140	45	176	52	54	70	180	112	15	121.5	12	16	428
132 S	... 130 ... 131	2 to 8 2	216	53	256	267.5	258	217	162	250	81	140	49	180	55	54	89	228	132	17	144	12	16	515
132 M	... 133 ... 134	4 to 8 6	216	53	256	267.5	258	217	162	250	81	178	49	218	55	54	89	190	132	17	144	12	16	515
160 M	... 163 ... 164	2 to 8 2 and 8	254	60	300	323	280	239	162	250	81	210	57	256	40	54	108	238	160	20	148	15	19	641
160 L	... 166	2 to 8	254	60	300	323	314	246	216	250	95	254	57	300	40	96	108	194	160	20	148	15	19	641

1) Measured across the screw heads.

2) K09 and K10 from frame size 90 upwards.

Squirrel-cage motors Dimensions

1MA6 · Frame sizes 71 M to 160 L

IM B 35 · For flange dimensions, see Page 7/20 (Z = Number of fixing holes)

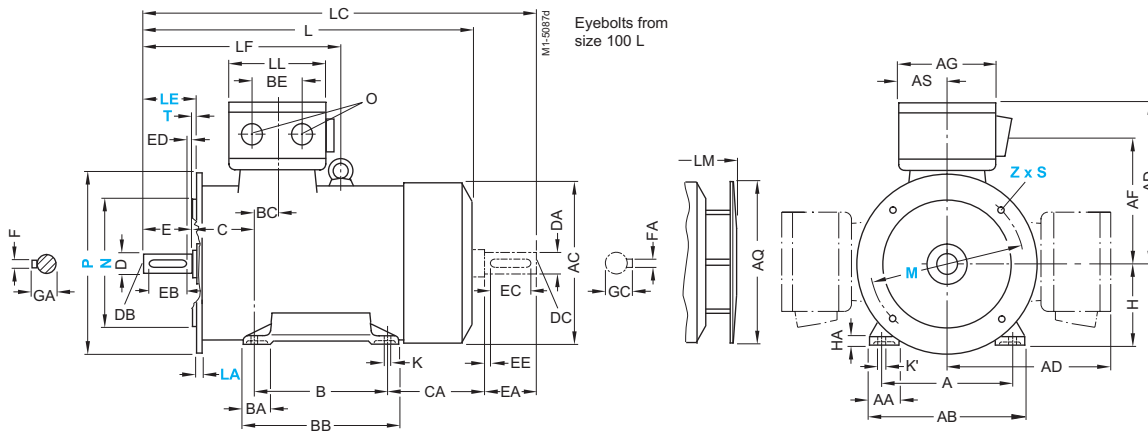

IM B 14 – For 1M6 frame sizes 71 M to 90 L · For flange dimensions, see Page 7/20 (Z = Number of fixing holes)

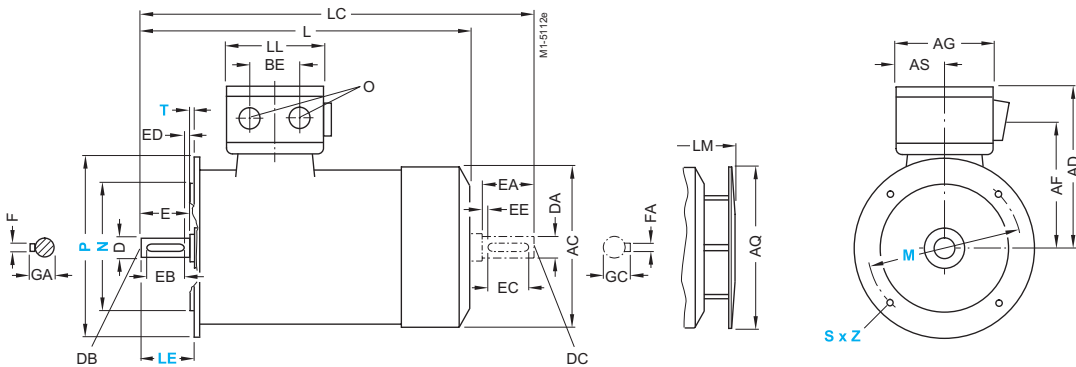

LC	LF	LL	LM	O	Drive-end shaft extension							Non-drive-end shaft extension						
					D	DB	E	EB	ED	F	GA	DA	DC	EA	EC	EE	FA	GC
339	-	132	327	2 x M25 x 1.5	14	M 5	30	22	4	5	16	14	M 5	30	22	4	5	16
386	-	132	362	2 x M25 x 1.5	19	M 6	40	32	4	6	21.5	19	M 6	40	32	4	6	21.5
458	-	162	434.5	2 x M25 x 1.5	24	M 8	50	40	5	8	27	24	M 8	50	40	5	8	27
508	-	162	477.5	2x M32 x 1.5	28	M 10	60	50	5	8	31	28	M 10	60	50	5	8	31
510	-	162	479.5	2x M32 x 1.5	28	M 10	60	50	5	8	31	28	M 10	60	50	5	8	31
617	-	162	567.5	2x M32 x 1.5	38	M 12	80	70	5	10	41	38	M 12	80	70	5	10	41
617	-	162	567.5	2x M32 x 1.5	38	M 12	80	70	5	10	41	38	M 12	80	70	5	10	41
776	383	162	693.5	2 x M40 x 1.5	42	M 16	110	90	10	12	45	42	M 16	110	90	10	12	45
776	383	190	693.5	2 x M40 x 1.5	42	M 16	110	90	10	12	45	42	M 16	110	90	10	12	45

Squirrel-cage motors

Dimensions

1MJ6, 1MJ7 · Frame sizes 180 M to 315 M,
1MJ8 · Frame sizes 315 M to 355

IM B 35 · For flange dimensions, see Page 7/20 (Z = Number of fixing holes)

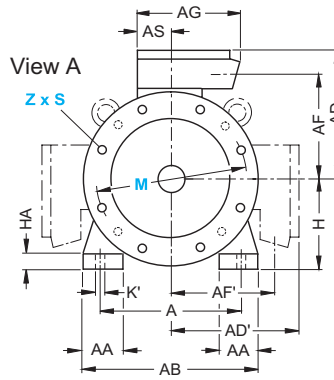
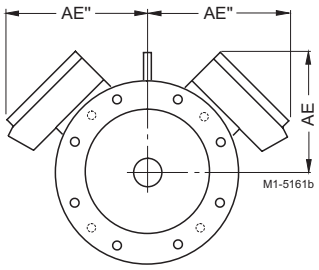
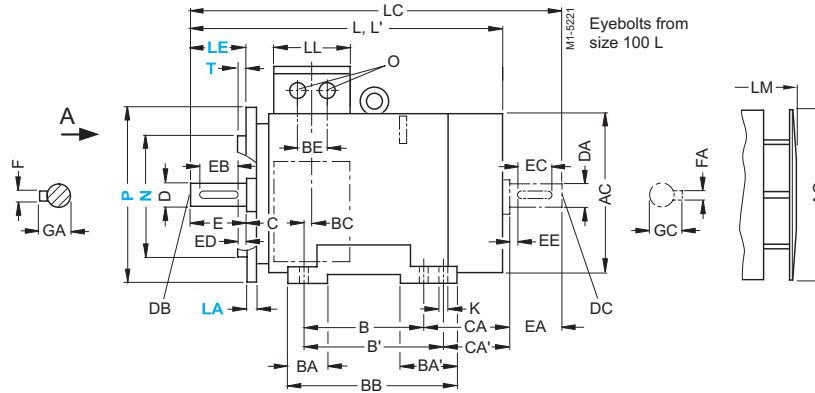
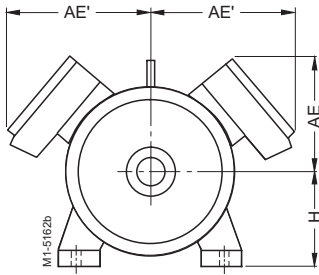

Frame sizes 180 M/L, 225 S/M, 280 S/M and 315 S/M have housing feet 2 drilled holes at NDE.

CA	H	HH	HA	K	K'	L	L ⁽²⁾	L ⁽³⁾	LL	LM	LM ⁽²⁾	O	Drive-end shaft extension					Non-drive-end shaft extension								
													D	DB	E	EB	ED	F	GA	DA	DC	EA	EC	EE	FA	GC
-	180	156	26	15	20	715	770	841	164	796.5	885	2 x M 40 x 1.5	48	M 16	110	100	5	14	51.5	48	M 16	110	100	5	14	51.5
221	180	156	26	15	20	715	-	841	164	796.5	-	2 x M 40 x 1.5	48	M 16	110	100	5	14	51.5	48	M 16	110	100	5	14	51.5
-	200	175	34	19	25	771.5	825	897	197	853	910	2 x M 50 x 1.5	55	M 20	110	100	5	16	59	48	M 16	110	100	5	14	51.5
-	200	175	34	19	25	771.5	-	825	197	853	-	2 x M 50 x 1.5	55	M 20	110	100	5	16	59	55	M 20	110	100	5	16	59
-	225	174	34	19	25	839	-	954	197	939	-	2 x M 50 x 1.5	60	M 20	140	125	10	18	64	55	M 20	110	100	5	16	59
244	225	174	34	19	25	809	855	924	197	909	955	2 x M 50 x 1.5	55	M 20	110	100	5	16	59	48	M 16	110	100	5	14	51.5
-	250	207	42	24	30	930	1010	1050	234	1035	1110	2 x M 63 x 1.5	60	M 20	140	125	10	18	64	55	M 20	110	100	5	16	59
-	280	220	42	24	30	1010	-	1080	234	1120	-	2 x M 63 x 1.5	65	M 20	140	125	10	18	69	60	M 20	140	125	10	18	64
266	280	220	42	24	30	1010	1080	1155	234	1120	1230	2 x M 63 x 1.5	65	M 20	140	125	10	18	69	60	M 20	140	125	10	18	64
-	315	248	56	28	35	1114	1185	1260	266	1224	1295	2 x M 63 x 1.5	65	M 20	140	125	10	18	69	60	M 20	140	125	10	18	64
-	315	248	56	28	35	1114	-	1290	266	1250	-	2 x M 63 x 1.5	80	M 20	140	125	10	22	85	70	M 20	140	125	10	20	74.5
307	315	248	56	28	35	1114	1185	1260	266	1224	1295	2 x M 63 x 1.5	65	M 20	140	125	10	18	69	60	M 20	140	125	10	18	64
-	315	248	56	28	35	1114	-	1290	266	1250	-	2 x M 63 x 1.5	80	M 20	140	125	10	22	85	70	M 20	140	125	10	20	74.5
-	315	468	30	28	28	1241	-	1440	-	1404	-	2 x M 63 x 1.5	65	M 20	140	125	18	69	65	M 20	140	125	18	69	69	
-	315	468	30	28	28	1343	-	1563	-	1455	-	2 x M 63 x 1.5	80	M 20	170	140	22	85	80	M 20	170	140	22	85	85	
-	315	468	30	28	28	1343	-	1563	-	1455	-	2 x M 63 x 1.5	80	M 20	170	140	22	85	80	M 20	170	140	22	85	85	
-	315	513	30	28	28	1351	-	1550	-	1514	-	2 x M 63 x 1.5	65	M 20	140	125	18	69	65	M 20	140	125	18	69	69	
-	315	513	30	28	28	1453	-	1673	-	1565	-	2 x M 63 x 1.5	80	M 20	170	140	22	85	80	M 20	170	140	22	85	85	
-	355	-	30	28	28	1650	1590	-	-	1750	-	35 - 75	75	M 20	140	125	20	79.5	75	M 20	140	125	20	79.5	95	
-	355	-	30	28	28	1680	1640	-	-	1800	-	35 - 75	90	M 24	170	140	25	95	90	M 24	170	140	25	95	95	
-	355	-	30	28	28	1680	1640	-	-	1800	-	35 - 75	90	M 24	170	140	25	95	90	M 24	170	140	25	95	95	
-	355	-	30	28	28	1780	1725	-	-	1884	-	35 - 75	75	M 20	140	125	20	79.5	75	M 20	140	125	20	79.5	95	
-	355	-	30	28	28	1810	1775	-	-	1934	-	35 - 75	90	M 24	170	140	25	95	90	M 24	170	140	25	95	95	
-	355	-	30	28	28	1810	1775	-	-	1934	-	35 - 75	90	M 24	170	140	25	95	90	M 24	170	140	25	95	95	

Squirrel-cage motors

Dimensions

Flange dimensions

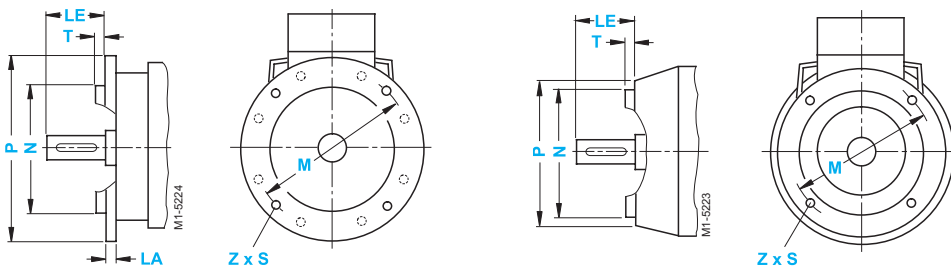

In EN 50347, flange FF with clearance holes and flange FT with tapped holes are assigned to the frame sizes.
The DIN 42948 standard with flanges A and C remains valid. See the assignment table below.
(Z = Number of fixing holes)

Size	Design, flange type	Flange with		Dimension drawing according to IEC								
		clearance holes (FF/A)	tapped holes (FT/C)	LA	LE	M	N	P	S	T	Z	
		acc. to EN 50 347	acc. to DIN 42 948									
1LA5, 1LA6, 1LA7, 1LA9, 1LG4, 1LG6, 1MA6, 1MA7, 1MJ6, and 1MJ7 motors												
56	IM B5 flange	FF 100	A120	8	20	100	80	120	7	3	4	
	IM B14 standard flange	FT 65	C 80	–	20	65	50	80	M 5	2.5	4	
	IM B14 special flange	FF 85	C 105	–	20	85	70	105	M 6	2.5	4	
63	IM B5 flange	FF 115	A140	8	23	115	95	140	10	3	4	
	IM B14 standard flange	FT 75	C 90	–	23	75	60	90	M 5	2.5	4	
	IM B14 special flange	FT 100	C 120	–	23	100	80	120	M 6	3	4	
71	IM B5 flange	FF 130	A160	9	30	130	110	160	10	3.5	4	
	IM B14 standard flange	FT 85	C 105	–	30	85	70	105	M 6	2.5	4	
	IM B14 special flange	FT 115	C 140	–	30	115	95	140	M 8	3	4	
80	IM B5 flange	FF 165	A200	10	40	165	130	200	12	3.5	4	
	IM B14 standard flange	FT 100	C 120	–	40	100	80	120	M 6	3	4	
	IM B14 special flange	FT 130	C 160	–	40	130	110	160	M 8	3.5	4	
90	IM B5 flange	FF 165	A200	10	50	165	130	200	12	3.5	4	
	IM B14 standard flange	FT 115	C 140	–	50	115	95	140	M 8	3	4	
	IM B14 special flange	FT 130	C 160	–	50	130	110	160	M 8	3.5	4	
100	IM B5 flange	FF 215	A250	11	60	215	180	250	14.5	4	4	
	IM B14 standard flange	FT 130	C 160	–	60	130	110	160	M 8	3.5	4	
	IM B14 special flange	FT 165	C 200	–	60	165	130	200	M 10	3.5	4	
112	IM B5 flange	FF 215	A250	11	60	215	180	250	14.5	4	4	
	IM B14 standard flange	FT 130	C 160	–	60	130	110	160	M 8	3.5	4	
	IM B14 special flange	FT 165	C 200	–	60	165	130	200	M 10	3.5	4	
132	IM B5 flange	FF 265	A300	12	80	265	230	300	14.5	4	4	
	IM B14 standard flange	FT 165	C 200	–	80	165	130	200	M 10	3.5	4	
	IM B14 special flange	FT 215	C 250	–	80	215	180	250	M 12	4	4	
160	IM B5 flange	FF 300	A350	13	110	300	250	350	18.5	5	4	
	IM B14 standard flange	FT 215	C 250	–	110	215	180	250	M 12	4	4	
	IM B14 special flange	FT 250	C 300	–	110	265	230	300	M 12	4	4	
180	IM B5 flange	FF 300	A350	13	110	300	250	350	18.5	5	4	
200	IM B5 flange	FF 350	A400	15	110	350	300	400	18.5	5	4	
225 2-pole 4-pole to 8-pole	IM B5 flange	FF 400	A450	16	110 140	400	350	450	18.5	5	8	
250	IM B5 flange	FF 500	A550	18	140	500	450	550	22	6	8	
280	IM B5 flange	FF 500	A550	18	140	500	450	550	22	6	8	
315 2-pole 4-pole to 8-pole	IM B5 flange	FF 600	A660	22	140 170	600	550	660	22	6	8	
1LA8, 1MJ8 motors												
315 2-pole 4-pole to 8-pole	IM B5 flange	–	–	25 (22)	140 170	740 (600)	680 (550)	800 (660)	22 (24)	6	8	
	355 2-pole 4-pole to 8-pole	IM B5 flange	–	–	25 170	840 (740)	780 (680)	900 (800)	22 (24)	6	8	
400 2-pole 4-pole to 8-pole	IM B5 flange	–	–	28	170 210	940	880	1000	22	6	8	
450 2-pole 4-pole to 8-pole	IM B5 flange	–	–	30	170 210	1080	1000	1150	26	6	8	

■ The dimensions in brackets apply to 1MJ8 motors.